

VÝMENNÁ ELEKTRODA NE Z MATERIÁLU CuCrZr

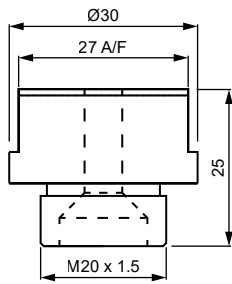

VÝMENNÁ ELEKTRODA NE-ELK S ELKANITEOVOU VRSTVOU

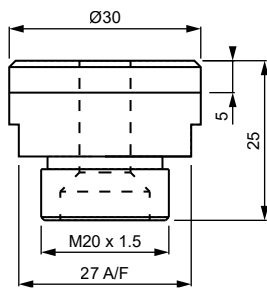

Skratky špeciálnych prevedení:
COL – s golierom
T/LESS – bez závitů

PRUŽINA POD KOLÍK

OZNAČENIE PRUŽINY	Ød	ØD	L
TL0840	1	8	40
TL1040	1	10	40

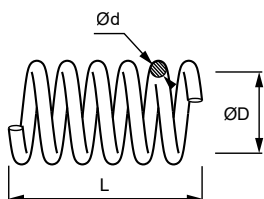

VÝMENNÉ ELEKTRODY A POKERAMIZOVANÉ KOLÍKY

VEĽKOSŤ MATICE	OTVOR V PLECHU Ø	POKERAMIZOVANÝ KOLÍK	VÝMENNÁ ELEKTRODA	
			CuCrZr	ELKANITE
M3				
M3	4.0	CPM3C	NECPM3	NECPM3:ELK
M4				
M4	5.0	CP1	NE1	NE1:ELK
M4	6.0	CP2	NE2	NE2:ELK
M4	6.65	CP30	NE17	NE17:ELK
M4	7.0	CP11C	NE3	NE3:ELK
M5				
M5	5.5	CP43	NE13	NE13:ELK
M5	6.0	CP3	NE2	NE2:ELK
M5	6.1	CP3-6	NE2-6	NE2-6:ELK
M5	7.0	CP4	NE3	NE3:ELK
M5	7.5	CP70C	NE11	NE11:ELK
M6				
M6	6.0	CP18C	NE2	NE2:ELK
M6	6.5	CP21	NE17	NE17:ELK
M6	7.0	CP5	NE3	NE3:ELK
M6	7.1	CP5-7/CP5-7C	NE3-7	NE3-7:ELK
M6	7.5	CP19	NE11	NE11:ELK
M6	8.0	CP6	NE4	NE4:ELK
M6	8.25	CP72C	NE35	NE35:ELK
M6 COL	8.7	CP67C	NE37	NE37:ELK
M6	9.0	CP71C	NE5	NE5:ELK
M6	9.65	CP41C	NE10	NE10:ELK
M6 COL	10.0	CP17C	NE6	NE6:ELK
M6 T/LESS	7.0	CP23	NE3	NE3:ELK
M6 T/LESS	7.5	CP14C	NE11	NE11:ELK
M8				
M8	8.5	CP31	NE20	NE20:ELK
M8	8.75	CP49C	NE37	NE37:ELK
M8	9.0	CP7/CP7C	NE5	NE5:ELK
M8	9.1	CP7-9	NE5	NE5:ELK
M8	9.5	CP16	NE10	NE10:ELK
M8	10.0	CP8	NE6	NE6:ELK
M8	10.1	CP8-10	NE6	NE6:ELK
M8	10.5	CP22	NE18	NE18:ELK
M8	11.0	CP66C	NE7	NE7:ELK
M8	11.2	CP73C	NE41	NE41:ELK
M8 COL	11.3	CP42-11.2	NE42	NE42:ELK
M8 COL	12.2	CP42	NE8	NE8:ELK
M8 T/LESS	8.75	CP50C	NE37	NE37:ELK
M8 T/LESS	9.0	CP24	NE5	NE5:ELK
M8 T/LESS	9.5	CP13C	NE10	NE10:ELK
M8 T/LESS	10.0	CP25C	NE6	NE6:ELK
M8 T/LESS	11.25	CP63C	NE7	NE7:ELK
M8 T/LESS	13.0	CP75C	NE12	NE12:ELK

ZOSTAVY PRE NAVAROVANIE MATÍC M3-M8 S POKERAMIZOVANÝM KOLÍKOM CP

Pro
Spot

DRŽIAKY B1 S NEPRIAMYM CHLADENÍM

OZNAČENIE DRŽIAKA S NEPRIAMYM CHLADENÍM	M	ØD	ØT	L	G	F	ØB
B1	M20×1.5	30	19,5°	65	G1/8"	G1/8"	44
B1-20110	M20×1.5	30	20, 1:10	65	G1/8"	G1/8"	44
B1-18110	M20×1.5	30	18, 1:10	65	G1/8"	G1/8"	44
B1-16110	M20×1.5	30	16, 1:10	65	G1/8"	G1/8"	44
B1-x	Ďalšie rozmery vyrábame na zákazku.						

Držiaky sú dodávané s pružinou, rýchlospojkou na stlačený vzduch (pripojenie na Ø6 hadicu).

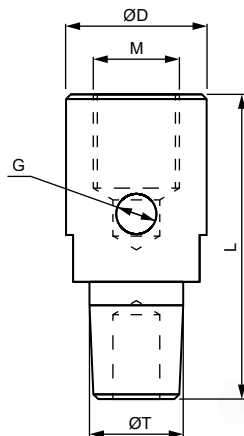

VÝMENNÁ ELEKTRODA S ELKANITEVOVOU VRSTVOU



POLOHOVACÍ KOLÍK



PRUŽINA



DRŽIAK ELEKTRODY



RÝCHLOSPOJKA NA STLAČENÝ VZDUCH



DRŽIAKY B1WC S PRIAMYM CHLADENÍM

OZNAČENIE DRŽIAKA S PRIAMYM CHLADENÍM	M	ØD	ØT	L	G	F	ØB
B1WC	M20×1.5	30	19,5°	65	G1/8"	G1/8"	44
B1-20110WC	M20×1.5	30	20, 1:10	65	G1/8"	G1/8"	44
B1-18110WC	M20×1.5	30	18, 1:10	65	G1/8"	G1/8"	44
B1-16110WC	M20×1.5	30	16, 1:10	65	G1/8"	G1/8"	44
B1-xWC	Ďalšie rozmery vyrábame na zákazku.						

Držiaky sú dodávané s pružinou, rýchlospojkou na stlačený vzduch (pripojenie na Ø6 hadicu) a rýchlospojkou na vodné chladenie (pripojenie na Ø8 hadicu).

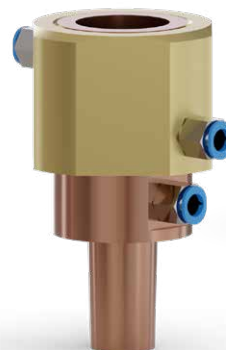
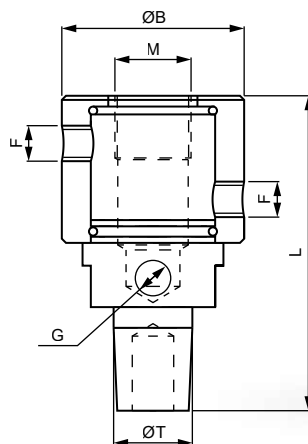

VÝMENNÁ ELEKTRODA NE Z MATERIÁLU CuCrZr

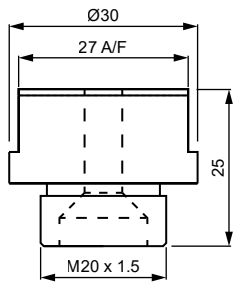

VÝMENNÁ ELEKTRODA NE-ELK S ELKANITEOVOU VRSTVOU

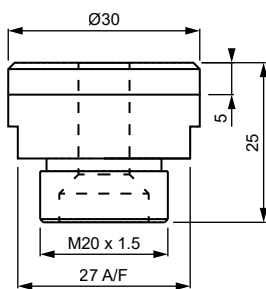

PRUŽINA POD KOLÍK

OZNAČENIE PRUŽINY	Ød	ØD	L
TL0840	1	8	40
TL1040	1	10	40

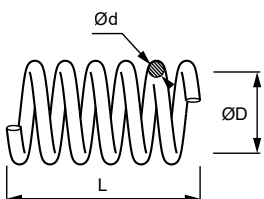

VÝMENNÉ ELEKTRODY A POKERAMIZOVANÉ KOLÍKY

VEĽKOSŤ MATICE	OTVOR V PLECHU Ø	POKERAMIZOVANÝ KOLÍK	VÝMENNÁ ELEKTRODA	
			CuCrZr	ELKANITE
M10				
M10	11.0	CP9/CP9C	NE7	NE7:ELK
M10	11.5	CP20	NE16	NE16:ELK
M10	11.7	CP44C	NE8	NE8:ELK
M10	12.0	CP10	NE8	NE8:ELK
M10	12.2	CP48	NE8	NE8:ELK
M10	12.4	CP55C	NE14	NE14:ELK
M10	13.0	CP52C	NE12	NE12:ELK
M10	14.5	CP53C	NE25	NE25:ELK
M10 T/LESS	11.0	CP26C	NE7	NE7:ELK
M10 T/LESS	11.5	CP27C	NE16	NE16:ELK
M10 T/LESS	12.0	CP56C	NE8	NE8:ELK
M10 T/LESS	13.15	CP62C	NE12	NE12:ELK
M12				
M12	13.0	CP61C	NE12	NE12:ELK
M12	14.0	CP69C	NE27	NE27:ELK
M12	15.5	CP51C	NE45M22	NE45M22:ELK
M12 F	12.7	CP68	NE40	NE40:ELK
M12 F	13.0	CP47	NE12	NE12:ELK
M12 F	13.2	CP12-173	NE9M22	NE9M22:ELK
M12 F	13.4	CP12-175	NE44M22	NE44M22:ELK
M14				
M14	14.6	CP74C	NE80M22	NE80M22:ELK
INÉ				
1/4 UNF	8.0	CP28C	NE4	NE4:ELK
5/16 UNF	8.7	CP29C	NE20	NE20:ELK
5/16 UNF	8.95	CP59C	NE5	NE5:ELK
5/16 UNF COL	12.5	CP64C	NE14	NE14:ELK
7/16 UNF	11.65	CP60	NE43	NE43:ELK
7/16 UNF	12.0	CP15	NE8	NE8:ELK
7/16 UNF	12.6	CP76C	NE14	NE14:ELK
7/16 UNF	13.0	CP77C	NE12	NE12:ELK
7/16 UNF	16.2	CP54C	NE31M22	NE31M22:ELK
3/8 UNC	14.75	CP36	NE26	NE26:ELK
3/8 UNC	14.5	CP65C	NE25	NE25:ELK

Skratky špeciálnych prevedení:

COL – s golierom

T/LESS – bez závitov

F – s jemným závitom

UNF – norma s jemným závitom

UNC – norma s hrubým závitom

ZOSTAVY PRE NAVAROVANIE MATÍC M10-M14 S POKERAMIZOVANÝM KOLÍKOM CP

Pro
Spot

DRŽIAKY B1 S NEPRIAMYM CHLADENÍM

OZNAČENIE DRŽIAKA S NEPRIAMYM CHLADENÍM	M	ØD	ØT	L	G	F	ØB
B1	M20×1.5	30	19,5°	65	G1/8"	G1/8"	44
B1-20110	M20×1.5	30	20, 1:10	65	G1/8"	G1/8"	44
B1-18110	M20×1.5	30	18, 1:10	65	G1/8"	G1/8"	44
B1-16110	M20×1.5	30	16, 1:10	65	G1/8"	G1/8"	44
B1-x	Ďalšie rozmery vyrábame na zákazku.						

Držiačky sú dodávané s pružinou, rýchlospojkou na stlačený vzduch (pripojenie na Ø6 hadicu).

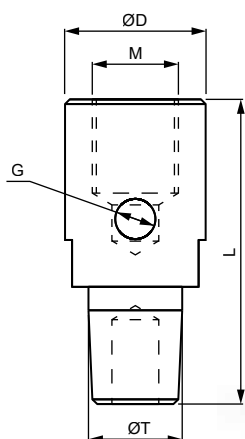

VÝMENNÁ ELEKTRODA S ELKANITEOVOU VRSTVOU



POLOHOVACÍ KOLÍK



PRUŽINA



DRŽIAK ELEKTRODY



RÝCHLOSPOJKA NA STLAČENÝ VZDUCH



DRŽIAKY B1WC S PRIAMYM CHLADENÍM

OZNAČENIE DRŽIAKA S PRIAMYM CHLADENÍM	M	ØD	ØT	L	G	F	ØB
B1WC	M20×1.5	30	19,5°	65	G1/8"	G1/8"	44
B1-20110WC	M20×1.5	30	20, 1:10	65	G1/8"	G1/8"	44
B1-18110WC	M20×1.5	30	18, 1:10	65	G1/8"	G1/8"	44
B1-16110WC	M20×1.5	30	16, 1:10	65	G1/8"	G1/8"	44
B1-xWC	Ďalšie rozmery vyrábame na zákazku.						

Držiačky sú dodávané s pružinou, rýchlospojkou na stlačený vzduch (pripojenie na Ø6 hadicu) a rýchlospojkou na vodné chladenie (pripojenie na Ø8 hadicu).

