

DOCERAM
ADVANCED CERAMIC SOLUTIONS

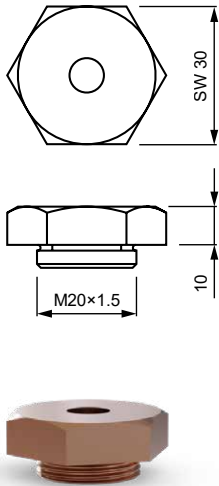

Cerazur



VÝMENNÉ ELEKTRODY

OTVOR V PLECHU ØD	SW 30	OTVOR V PLECHU ØD	SW 30
8.5	1111-ZK-20104	10.1	1111-ZK-20120
8.6	1111-ZK-20105	10.2	1111-ZK-20121
8.7	1111-ZK-20106	10.3	1111-ZK-20122
8.8	1111-ZK-20107	10.4	1111-ZK-20123
8.9	1111-ZK-20108	10.5	1111-ZK-20124
9.0	1111-ZK-20109	10.6	1111-ZK-20125
9.1	1111-ZK-20110	10.7	1111-ZK-20126
9.2	1111-ZK-20111	10.8	1111-ZK-20127
9.3	1111-ZK-20112	10.9	1111-ZK-20128
9.4	1111-ZK-20113	11.0	1111-ZK-20129
9.5	1111-ZK-20114	11.1	1111-ZK-20130
9.6	1111-ZK-20115	11.2	1111-ZK-20131
9.7	1111-ZK-20116	11.3	1111-ZK-20132
9.8	1111-ZK-20117	11.4	1111-ZK-20133
9.9	1111-ZK-20118	11.5	1111-ZK-20134
10.0	1111-ZK-20119		

KERAMICKÉ KOLÍKY CERAZUR

OTVOR V PLECHU ØD	KRÁTKY	DLHÝ	S GOLIEROM
8.5	8228-ZK-11053	8228-ZK-10053	8228-ZK-10353
8.6	8228-ZK-11054	8228-ZK-10054	8228-ZK-10354
8.7	8228-ZK-11055	8228-ZK-10055	8228-ZK-10355
8.8	8228-ZK-11056	8228-ZK-10056	8228-ZK-10356
8.9	8228-ZK-11057	8228-ZK-10057	8228-ZK-10357
9.0	8228-ZK-11058	8228-ZK-10058	8228-ZK-10358
9.1	8228-ZK-11059	8228-ZK-10059	8228-ZK-10359
9.2	8228-ZK-11060	8228-ZK-10060	8228-ZK-10360
9.3	8228-ZK-11061	8228-ZK-10061	8228-ZK-10361
9.4	8228-ZK-11062	8228-ZK-10062	8228-ZK-10362
9.5	8228-ZK-11063	8228-ZK-10063	8228-ZK-10363
9.6	8228-ZK-11064	8228-ZK-10064	8228-ZK-10364
9.7	8228-ZK-11065	8228-ZK-10065	8228-ZK-10365
9.8	8228-ZK-11066	8228-ZK-10066	8228-ZK-10366
9.9	8228-ZK-11067	8228-ZK-10067	8228-ZK-10367
10.0	8228-ZK-11068	8228-ZK-10068	8228-ZK-10368
10.1	8228-ZK-11069	8228-ZK-10069	8228-ZK-10369
10.2	8228-ZK-11070	8228-ZK-10070	8228-ZK-10370
10.3	8228-ZK-11071	8228-ZK-10071	8228-ZK-10371
10.4	8228-ZK-11072	8228-ZK-10072	8228-ZK-10372
10.5	8228-ZK-11073	8228-ZK-10073	8228-ZK-10373
10.6	8228-ZK-11074	8228-ZK-10074	8228-ZK-10374
10.7	8228-ZK-11075	8228-ZK-10075	8228-ZK-10375
10.8	8228-ZK-11076	8228-ZK-10076	8228-ZK-10376
10.9	8228-ZK-11077	8228-ZK-10077	8228-ZK-10377
11.0	8228-ZK-11078	8228-ZK-10078	8228-ZK-10378



Na objednávku dodávame aj kolíky z materiálu Volcera.
Kód produktu: „8440-ZK-xxxx“ („xxxx“ je posledné päťčísle v tabuľke)

ZOSTAVY PRE NAVAROVANIE MATÍC M8 CHLADENÉ VODOU

Pro
Spot

DRŽIAKY ELEKTRÓD

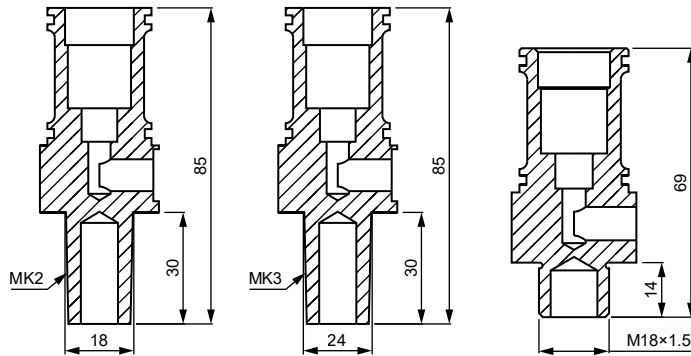

VEĽKOSŤ MATICE	KUŽEL MK2	KUŽEL MK3	ZÁVIT M18x1.5
M8	1111-ZK-20542	1111-ZK-20543	1111-ZK-20562

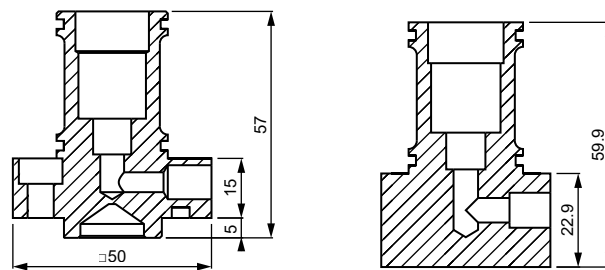

VEĽKOSŤ MATICE	R-TYP	C-TYP
M8	1111-ZK-20642	1111-ZK-20662

CHLADIACI KRÚŽOK

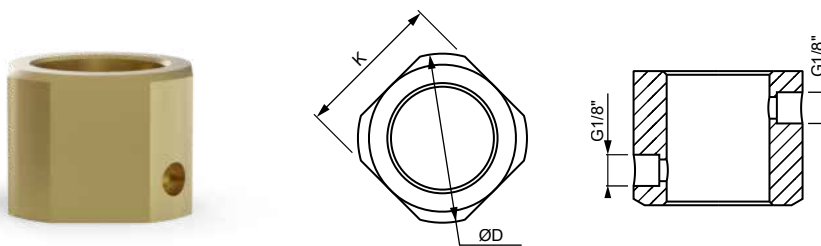

VEĽKOSŤ MATICE	OZNAČENIE	ØD	K
M4 až M8	1113-ZK-19766	46	40
C-typ M4 až M8	1113-ZK-19766	46	40

PRÍSLUŠENSTVO K DRŽIAKOM ELEKTRÓD

PRUŽINA



O-KRÚŽOK



RÝCHLOSPOJKA



DĹŽKA DRŽIAKA	OZNAČENIE
od 40 mm	1112-ZK-12206

TYP DRŽIAKA	OZNAČENIE
Ø28	1123-ZK-16436

—	OZNAČENIE
prívod stlačeného vzduchu G1/8"-Ø6	1116-ZK-12353

ADVANCED CERAMIC SOLUTIONS
DOCERAM[®]

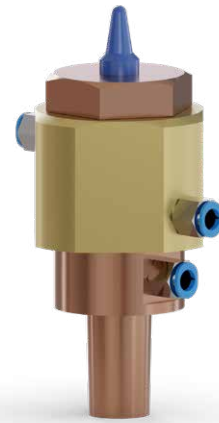

VÝMENNÁ
ELEKTRÓDA

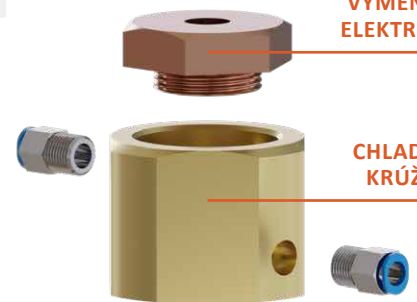

CHLADIACI
KRÚŽOK

POLOHOVACÍ
KOLÍK



PRUŽINA



DRŽIAK
ELEKTRÓDY S
O-KRÚŽKAMI



RÝCHLOSPOJKA
NA STLAČENÝ
VZDUCH

