

KRÁTKY

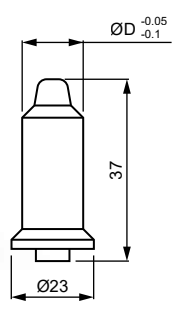

DLHÝ

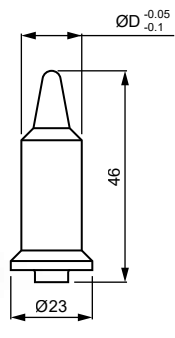

S GOLIEROM

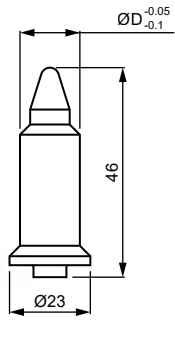

VÝMENNÉ ELEKTRODY

OTVOR V PLECHU ØD	SW 41	OTVOR V PLECHU ØD	SW 41
17.0	1111-ZK-10244	18.3	1111-ZK-10257
17.1	1111-ZK-10245	18.4	1111-ZK-10258
17.2	1111-ZK-10246	18.5	1111-ZK-10259
17.3	1111-ZK-10247	18.6	1111-ZK-10260
17.4	1111-ZK-10248	18.7	1111-ZK-10261
17.5	1111-ZK-10249	18.8	1111-ZK-10262
17.6	1111-ZK-10250	18.9	1111-ZK-10263
17.7	1111-ZK-10251	19.0	1111-ZK-10264
17.8	1111-ZK-10252	19.1	1111-ZK-10265
17.9	1111-ZK-10253	19.2	1111-ZK-10266
18.0	1111-ZK-10254	19.3	1111-ZK-10267
18.1	1111-ZK-10255	19.4	1111-ZK-10268
18.2	1111-ZK-10256	19.5	1111-ZK-10269

KERAMICKÉ KOLÍKY CERAZUR

OTVOR V PLECHU ØD	KRÁTKY	DLHÝ	S GOLIEROM
17.0	8228-ZK-11147	8228-ZK-10147	8228-ZK-10447
17.1	8228-ZK-11148	8228-ZK-10148	8228-ZK-10448
17.2	8228-ZK-11149	8228-ZK-10149	8228-ZK-10449
17.3	8228-ZK-11150	8228-ZK-10150	8228-ZK-10450
17.4	8228-ZK-11151	8228-ZK-10151	8228-ZK-10451
17.5	8228-ZK-11152	8228-ZK-10152	8228-ZK-10452
17.6	8228-ZK-11153	8228-ZK-10153	8228-ZK-10453
17.7	8228-ZK-11154	8228-ZK-10154	8228-ZK-10454
17.8	8228-ZK-11155	8228-ZK-10155	8228-ZK-10455
17.9	8228-ZK-11156	8228-ZK-10156	8228-ZK-10456
18.0	8228-ZK-11157	8228-ZK-10157	8228-ZK-10457
18.1	8228-ZK-11158	8228-ZK-10158	8228-ZK-10458
18.2	8228-ZK-11159	8228-ZK-10159	8228-ZK-10459
18.3	8228-ZK-11160	8228-ZK-10160	8228-ZK-10460
18.4	8228-ZK-11161	8228-ZK-10161	8228-ZK-10461
18.5	8228-ZK-11162	8228-ZK-10162	8228-ZK-10462
18.6	8228-ZK-11163	8228-ZK-10163	8228-ZK-10463
18.7	8228-ZK-11164	8228-ZK-10164	8228-ZK-10464
18.8	8228-ZK-11165	8228-ZK-10165	8228-ZK-10465
18.9	8228-ZK-11166	8228-ZK-10166	8228-ZK-10466
19.0	8228-ZK-11167	8228-ZK-10167	8228-ZK-10467
19.1	8228-ZK-11168	8228-ZK-10168	8228-ZK-10468
19.2	8228-ZK-11169	8228-ZK-10169	8228-ZK-10469
19.3	8228-ZK-11170	8228-ZK-10170	8228-ZK-10470
19.4	8228-ZK-11171	8228-ZK-10171	8228-ZK-10471
19.5	8228-ZK-11172	8228-ZK-10172	8228-ZK-10472



Na objednávku dodávame aj kolíky z materiálu Volcera.  
Kód produktu: „8440-ZK-xxxxx“ („xxxxx“ je posledné päťčíslicie v tabuľke, napr. pre Ø17.0 je kód 8440-ZK-11147)

# ZOSTAVY PRE NAVAROVANIE MATÍC M16 CHLADENÉ VODOU

Pro Spot

## DRŽIAKY ELEKTRÓD

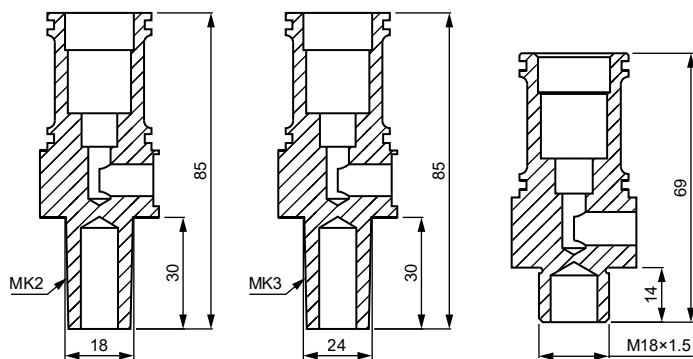

VEĽKOSŤ MATICE	KUŽEL MK2	KUŽEL MK3	ZÁVIT M18x1.5
M16	1111-ZK-20565	1111-ZK-20566	1111-ZK-20567

## CHLADIACI KRÚŽOK

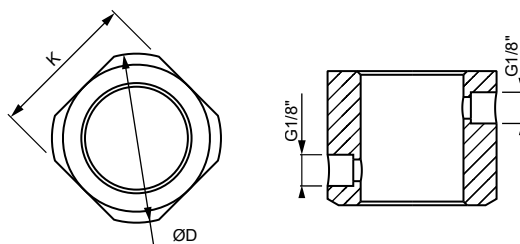

VEĽKOSŤ MATICE	OZNAČENIE	ØD	K
M16	1113-ZK-19770	65	56

## PRÍSLUŠENSTVO K DRŽIAKOM ELEKTRÓD

PRUŽINA



O-KRÚŽOK



RÝCHLOSPOJKA



DĹŽKA DRŽIAKA	OZNAČENIE
od 40 mm	1112-ZK-12207

TYP DRŽIAKA	OZNAČENIE
M16	1123-Z-77089

—	OZNAČENIE
prívod stlačeného vzduchu G1/8"-Ø6	1116-ZK-12353

DOCCERAM  
ADVANCED CERAMIC SOLUTIONS

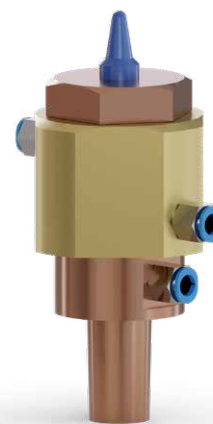

VÝMENNÁ  
ELEKTRÓDA

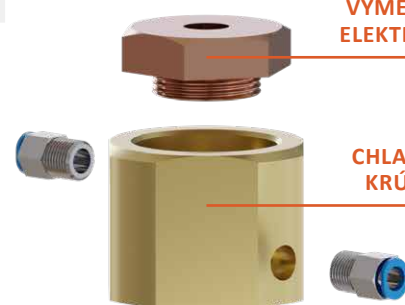

CHLADIACI  
KRÚŽOK

POLOHOVACÍ  
KOLÍK



PRUŽINA



DRŽIAK  
ELEKTRÓDY S  
O-KRÚŽKAMI



RÝCHLOSPOJKA  
NA STLAČENÝ  
VZDUCH

