

DOCERAM
ADVANCED CERAMIC SOLUTIONS

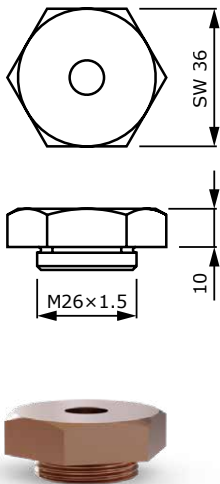

Cerazur

VÝMENNÉ ELEKTRODY

OTVOR V PLECHU ØD	SW 36	OTVOR V PLECHU ØD	SW 36
11.0	1111-ZK-20166	12.3	1111-ZK-20179
11.1	1111-ZK-20167	12.4	1111-ZK-20180
11.2	1111-ZK-20168	12.5	1111-ZK-20181
11.3	1111-ZK-20169	12.6	1111-ZK-20182
11.4	1111-ZK-20170	12.7	1111-ZK-20183
11.5	1111-ZK-20171	12.8	1111-ZK-20184
11.6	1111-ZK-20172	12.9	1111-ZK-20185
11.7	1111-ZK-20173	13.0	1111-ZK-20186
11.8	1111-ZK-20174	13.1	1111-ZK-20187
11.9	1111-ZK-20175	13.2	1111-ZK-20188
12.0	1111-ZK-20176	13.3	1111-ZK-20189
12.1	1111-ZK-20177	13.4	1111-ZK-20190
12.2	1111-ZK-20178	13.5	1111-ZK-20191

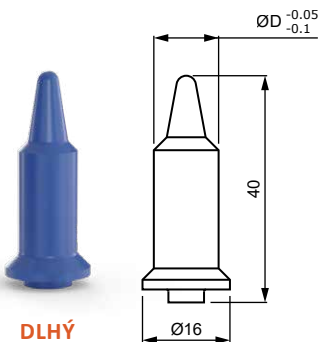

KERAMICKÉ KOLÍKY CERAZUR

OTVOR V PLECHU ØD	KRÁTKY	DLHÝ	S GOLIEROM
11.0	8228-ZK-11079	8228-ZK-10079	8228-ZK-10379
11.1	8228-ZK-11080	8228-ZK-10080	8228-ZK-10380
11.2	8228-ZK-11081	8228-ZK-10081	8228-ZK-10381
11.3	8228-ZK-11082	8228-ZK-10082	8228-ZK-10382
11.4	8228-ZK-11083	8228-ZK-10083	8228-ZK-10383
11.5	8228-ZK-11084	8228-ZK-10084	8228-ZK-10384
11.6	8228-ZK-11085	8228-ZK-10085	8228-ZK-10385
11.7	8228-ZK-11086	8228-ZK-10086	8228-ZK-10386
11.8	8228-ZK-11087	8228-ZK-10087	8228-ZK-10387
11.9	8228-ZK-11088	8228-ZK-10088	8228-ZK-10388
12.0	8228-ZK-11089	8228-ZK-10089	8228-ZK-10389
12.1	8228-ZK-11090	8228-ZK-10090	8228-ZK-10390
12.2	8228-ZK-11091	8228-ZK-10091	8228-ZK-10391
12.3	8228-ZK-11092	8228-ZK-10092	8228-ZK-10392
12.4	8228-ZK-11093	8228-ZK-10093	8228-ZK-10393
12.5	8228-ZK-11094	8228-ZK-10094	8228-ZK-10394
12.6	8228-ZK-11095	8228-ZK-10095	8228-ZK-10395
12.7	8228-ZK-11096	8228-ZK-10096	8228-ZK-10396
12.8	8228-ZK-11097	8228-ZK-10097	8228-ZK-10397
12.9	8228-ZK-11098	8228-ZK-10098	8228-ZK-10398
13.0	8228-ZK-11099	8228-ZK-10099	8228-ZK-10399



Na objednávku dodávame aj kolíky z materiálu Volcera.
Kód produktu: „8440-ZK-xxxx“ („xxxx“ je posledné
päťčísle v tabuľke, napr. pre Ø11.0 je kód 8440-ZK-11079)

ZOSTAVY PRE NAVAROVANIE MATÍC M10 CHLADENÉ VODOU

Pro
Spot

DRŽIAKY ELEKTRÓD

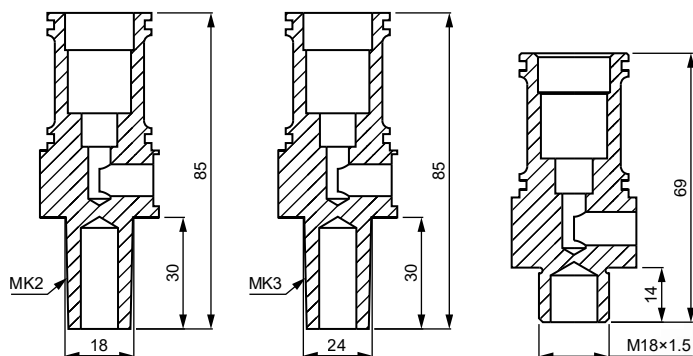

VEĽKOSŤ MATICE	KUŽEL MK2	KUŽEL MK3	ZÁVIT M18x1.5
M10	1111-ZK-20544	1111-ZK-20545	1111-ZK-20563

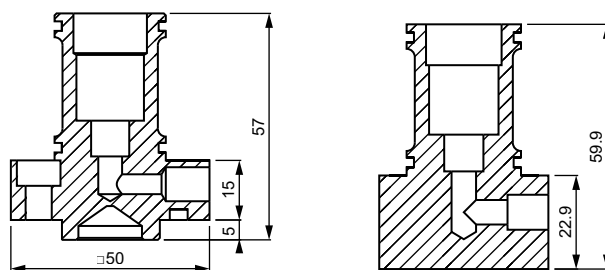

VEĽKOSŤ MATICE	R-TYP	C-TYP
M10	1111-ZK-10644	1111-ZK-10663

CHLADIACI KRÚŽOK

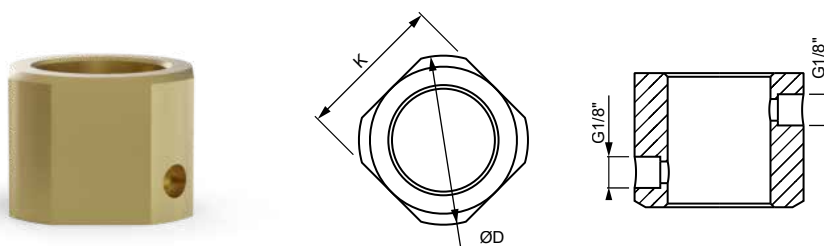

VEĽKOSŤ MATICE	OZNAČENIE	ØD	K
M10, M12	1113-ZK-19767	52	46
C-typ M10 až M12	1113-ZK-19769	52	46

PRÍSLUŠENSTVO K DRŽIAKOM ELEKTRÓD

PRUŽINA



O-KRÚŽOK



RÝCHLOSPOJKA



DĹŽKA DRŽIAKA	OZNAČENIE
od 40 mm	1112-ZK-12207

TYP DRŽIAKA	OZNAČENIE
Ø34	1123-ZK-26187

—	OZNAČENIE
prívod stlačeného vzduchu G1/8"-Ø6	1116-ZK-12353

ADVANCED CERAMIC SOLUTIONS
DOCERAM[®]

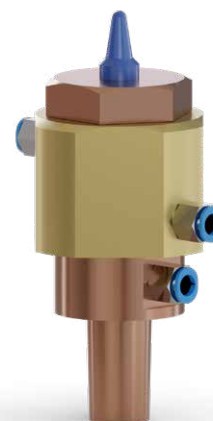

VÝMENNÁ
ELEKTRÓDA

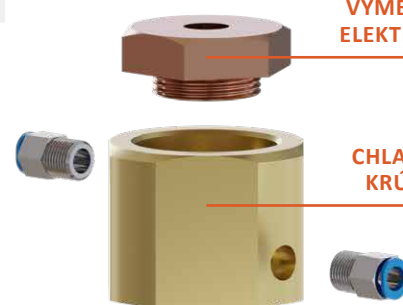

CHLADIACI
KRÚŽOK

POLOHOVACÍ
KOLÍK



PRUŽINA



DRŽIAK
ELEKTRÓDY S
O-KRÚŽKAMI



RÝCHLOSPOJKA
NA STLAČENÝ
VZDUCH

