

ELEKTRÓDY S VÝKYVNOU HLAVOU

OZNAČENIE		ØD1	ØD2	TL	L
UPÍNANIE 5°	UPÍNANIE 1:10				
SW1	SWT1	30	13	20	65
SW1-22	SWT1-22	22	13	20	65
SW2	SWT2	30	16	20	65
SW2-22	SWT2-22	22	16	20	65
SW3	SWT3	30	19	20	65
SWx	SWTx	Ďalšie rozmery vyrábame na zákazku.			

ODOLNÉ HORNÉ ELEKTRÓDY TE(T) S ELKANITEOVÝM POVRCHOM PRE NAVÁRANIE MATÍC

OZNAČENIE		ØD1	ØD2	TL	L
UPÍNANIE 5°	UPÍNANIE 1:10				
(1)					
TE13-75ELK	TET13-75ELK	13	—	20	75
TE16-75ELK	TET16-75ELK	16	—	25	75
TE19-75ELK	TET19-75ELK	19	—	25	75
(2)					
TE25-75ELK	TET25-75ELK	19	25	25	75
TE30-75ELK	TET30-75ELK	19	30	25	75
TE38-75ELK	TET38-75ELK	19	38	25	75
TE _x	TET _x	Ďalšie rozmery vyrábame na zákazku.			

ELKANITEOVÉ DISKY

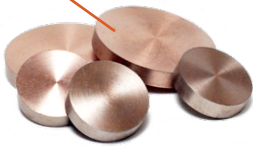

ELKANITEOVÝ POVRCH

MEDEŇÁ ELEKTRÓDA

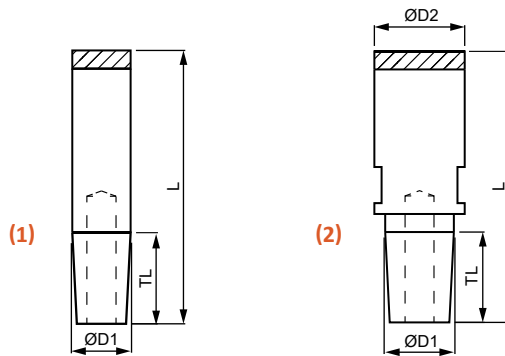

ODOLNÉ HORNÉ ELEKTRÓDY NEB(M) S ELKANITEOVÝM POVRCHOM PRE NAVÁRANIE MATÍC

OZNAČENIE	ØD1	M	L
NEB	30	M20×1.5	25
NEBM18	30	M18×1.5	25
NEBM22	30	M22×1.5	25
NEBM24	30	M24×1.5	25
NEB:ELK	30	M20×1.5	25
NEBM18:ELK	30	M18×1.5	25
NEBM22:ELK	30	M22×1.5	25
NEBM24:ELK	30	M24×1.5	25
NEB _x	Ďalšie rozmery vyrábame na zákazku.		

