

# Mig / Mag Torch

High Performance Air-Cooled 350 Amp. Mig Torch

ProSpot

welding & joining technologies

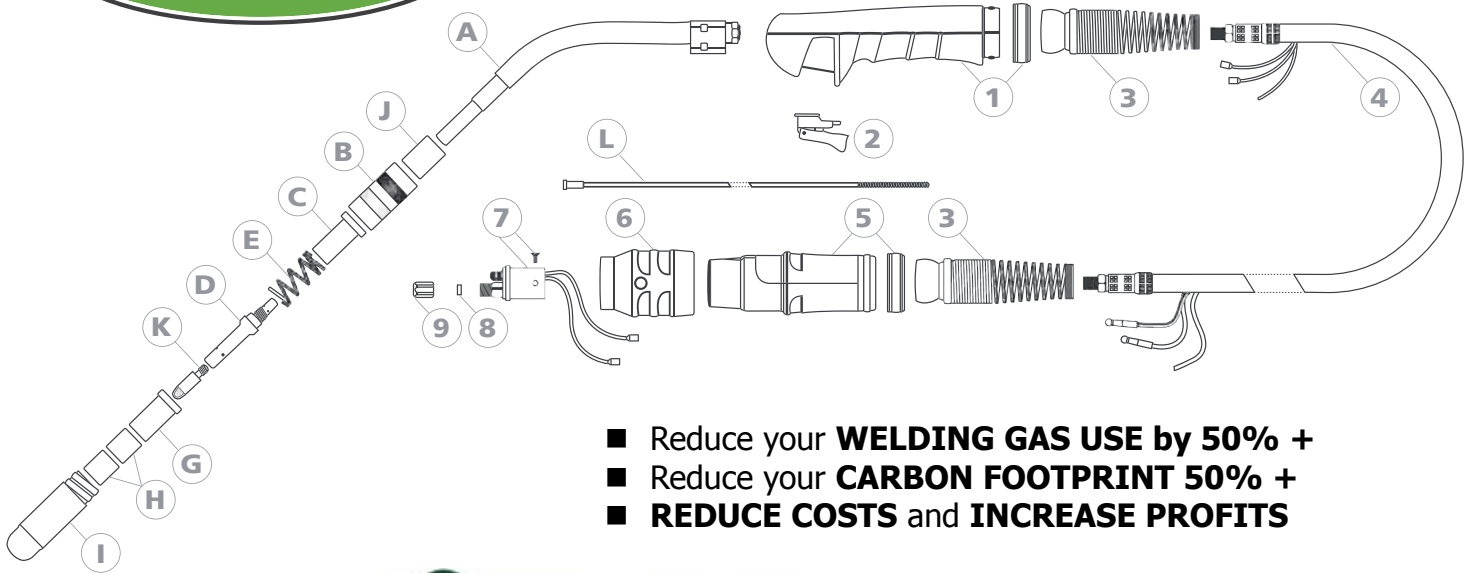

- Reduce your **WELDING GAS USE** by **50% +**
- Reduce your **CARBON FOOTPRINT** **50% +**
- **REDUCE COSTS** and **INCREASE PROFITS**



6L/mn

## Parts & Components

P/N	Description
1	NPT Handle (with ring, without Trigger)
2	GN Trigger for Handle
A	1110 Swan Neck for 350
B	1121 Shroud retainer for 350
C	1130 Insulation Spring 350
D	1140 Gas Tip Adaptor for 350
E	1150 Spring
G	1170.2 Insulation Bush for 350
H	1170.1 Ceramic Bush for 350
I	1181 Shroud for 350
J	1160 Insulation Ring for 350 Swan Neck
K	210 Contact Tip M8 — 1 mm
K	212 Contact Tip M8 — 1,2 mm
K	216 Contact Tip M8 — 1,6 mm

## Torches

TM3503	350 Amp. Redux MIG Torch - 3 m
TM3504	350 Amp. Redux MIG Torch - 4 m
TM3505	350 Amp. Redux MIG Torch - 5 m

P/N	Description
L	GM540 Guide Spiral liner 1,2-1,6 — 3 m
L	GM541 Guide Spiral liner 1,2-1,6 — 4 m
L	GM542 Guide Spiral liner 1,2-1,6 — 5 m
L	GM610 Guide Spiral liner Ptfе 1,2-1,6 — 3 m
L	GM611 Guide Spiral liner Ptfе 1,2-1,6 — 4 m
L	GM612 Guide Spiral liner Ptfе 1,2-1,6 — 5 m
3	NTRR Cable Support Spring
4	CC50xM Power Cable (3m / 4m / 5m)
5	NTCC Rear connector (with ring)
6	NTBDF Coupling Cap
7	NTCA Central Adaptor + Pan Head Screw
8	NTPBF Teflon® Ring
9	NTBFP Coupling Nut (long)



Prospot Limited - Unit C Riverside Industrial Estate  
 Atherstone Street - Fazeley - Tamworth - Staffordshire - B78 3RW  
 Telephone: 01827 254 829 - Fax: 01827 254 832  
 Email: sales@prospot.co.uk - Web: www.prospot.co.uk