

Ceramic Coated Sleeves

Part No	Stud Size	Dia A	Dia B	Length C
CSM4	M4	5.8	4.5	22
CS1	M5	7.0	5.6	17
CS2	M6	8.0	6.6	22
CS2-6	M6	7.6	6.0	25
CS3	M8	10.0	8.6	22
CS4	M10	12.0	10.6	22
CS5		10.9	9.5	22
CS6	M8	9.5	8.1	22
CS7	M8	12.0	8.25	18
CS9	M9	10.6	9.2	22
CS8	11	12.7	11.3	22
PFT5013M5	M5	8.0	6.0	37
PFT5013M6	M6	8.5	6.4	37
96869-12		9.5	7.4	37
PFT5013M8	M8	10.5	8.5	37
CSFD	M10	12.3	10.1	18
NYW2019	M10	13.0	10.8	37
PFT5013M10	M10	13.0	11.0	37
NYW2021		14.0	11.8	37
NYW2021-12.1	M12	14.0	12.1	37

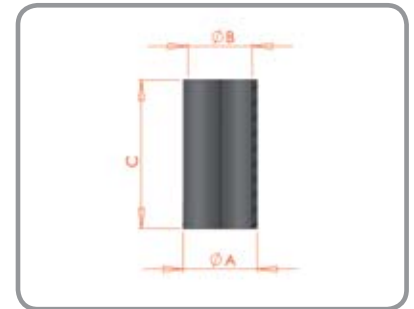
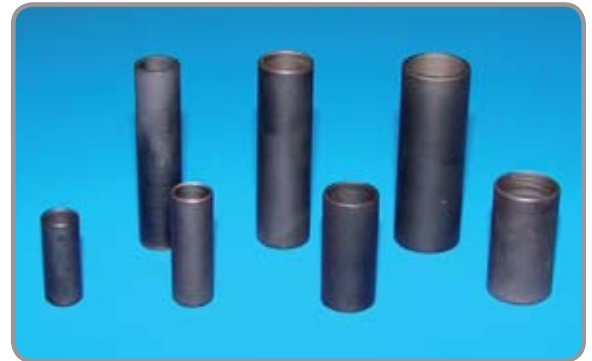

Stud Electrodes

Part No CuCrZr	Part No Elkanite	Stud Size	Dia A	Dia B	Lgth C	Thread
SE0	SE0ELK	M4	4.4	5.8	22.5	M20
SE1	SE1ELK	M5	6.5	7	22.5	M20
SE2	SE2ELK	M6	7.5	8	22.5	M20
SE3	SE3ELK	M8	9.5	10	22.5	M20
SE4	SE4ELK	M10	11.5	12	22.5	M20
SE25-CS1	SE25ELK-CS1	M5	6.5	7	22.5	M18
SE25-CS2	SE25ELK-CS2	M6	7.5	8	22.5	M18
SE25-CS3	SE25ELK-CS3	M8	9.5	10	22.5	M18
SE25-CS4	SE25ELK-CS4	M10	11.5	12	22.5	M18

